

Contribution from the Department of Chemistry, University of Nevada, Reno, Nevada 89557, and Institute of Chemistry, Faculty of Sciences, University of Belgrade, 11001 Belgrade, Yugoslavia

## Unique Properties of Ruthenium(II) Phosphole Complexes

Rahel Vac,<sup>1a</sup> John H. Nelson,<sup>\*1a</sup> Emil B. Milosavljević,<sup>1b</sup> and Ljiljana Solujić<sup>1b</sup>

Received August 24, 1988

Several ruthenium(II) complexes of  $\text{Ph}_3\text{P}$ , 1-phenyldibenzophosphole (DBP), and 1-phenyl-3,4-dimethylphosphole (DMPP) have been synthesized. A more general synthesis of *ttt*- $\text{RuCl}_2(\text{CO})_2(\text{PR}_3)_2$  has been developed. These complexes were characterized by infrared and NMR ( $^1\text{H}$ ,  $^{13}\text{C}\{^1\text{H}\}$ ,  $^{31}\text{P}\{^1\text{H}\}$ ) spectroscopy, and their solution behavior, including redox properties, was studied. The *ttt*- $\text{RuCl}_2(\text{CO})_2(\text{phosphole})_2$  complexes undergo ligand-redistribution reactions to form *mer-trans*- $\text{RuCl}_2(\text{CO})(\text{phosphole})_3$  and, presumably, a phosphole-deficient compound. These compounds were also investigated for their ability to catalyze the homogeneous hydrogenation and/or isomerization of allylbenzene at 100 °C and a hydrogen pressure of 100 psi in a 50/50 ethanol/benzene solution. Each of the complexes catalyzed both the hydrogenation of allylbenzene to propylbenzene and its isomerization to one or both of the internal isomers, *cis*- and *trans*- $\beta$ -methylstyrene. The turnover numbers for these processes are a function of the precatalyst geometry, the nature of the phosphorus ligand, and the presence or absence of coordinated carbon monoxide.

### Introduction

Reaction of a phosphine,  $\text{R}_3\text{P}$ , with  $[\text{RuCl}_2(\text{CO})_2]_n$  produces a variety of products.<sup>2,3</sup> The nature of these products depends upon the reaction conditions and the steric bulk of the phosphine.<sup>3</sup> At temperatures below 30 °C, 2 mol of  $\text{R}_3\text{P}$  react to form *ttt*- $\text{RuCl}_2(\text{CO})_2(\text{R}_3\text{P})_2$ . These complexes thermally isomerize by CO dissociation<sup>2,3</sup> to form the thermodynamically preferred *cct*- $\text{RuCl}_2(\text{CO})_2(\text{R}_3\text{P})_2$ . Similarly, 3 mol of a sterically small phosphine react at low temperatures to form *mer-trans*- $\text{RuCl}_2(\text{CO})(\text{R}_3\text{P})_3$ . These complexes also thermally isomerize but by phosphine dissociation to produce the thermodynamically preferred *mer-cis*- $\text{RuCl}_2(\text{CO})(\text{R}_3\text{P})_3$ . The same coordinatively unsaturated species,  $\text{RuCl}_2(\text{CO})(\text{R}_3\text{P})_2$ , likely exists as an intermediate in both these isomerizations<sup>3</sup> (Scheme 1).

Scheme 1 is somewhat simplified. The *ttt*- $\text{RuCl}_2(\text{CO})_2(\text{R}_3\text{P})_2$  species actually<sup>3</sup> isomerize by way of *ccc*- $\text{RuCl}_2(\text{CO})_2(\text{R}_3\text{P})_2$  as well, and in concentrated solutions, the dimers  $[\text{RuCl}_2(\text{CO})(\text{R}_3\text{P})_2]_2$  are formed.

Extensive research on transition-metal phosphine and phosphole<sup>4,5</sup> complexes has shown that for some transition-metal systems, phosphole chemistry is unique and cannot be predicted by comparison with related transition-metal phosphines.

We<sup>6</sup> and others<sup>7</sup> have shown that ruthenium(II) phosphine complexes are efficient homogeneous hydrogenation catalysts. Many of these complexes are not stable in solution but undergo facile ligand dissociation and/or geometric isomerization. In continuation of our studies<sup>6</sup> regarding the relationship between the nature and structure of the complexes present in solution and their catalytic efficiency, we have prepared and characterized a series of ruthenium(II) complexes of the types  $(\text{R}_3\text{P})_n\text{RuCl}_2$  ( $n = 3, 4$ ), *ttt*- and *cct*- $\text{RuCl}_2(\text{CO})_2(\text{R}_3\text{P})_2$ , and *mer-cis*- and *mer-trans*- $\text{RuCl}_2(\text{CO})(\text{R}_3\text{P})_3$  [ $\text{R}_3\text{P} = \text{Ph}_3\text{P}$ , 1-phenyldibenzophosphole (DBP), 1-phenyl-3,4-dimethylphosphole (DMPP)] and studied

Scheme 1

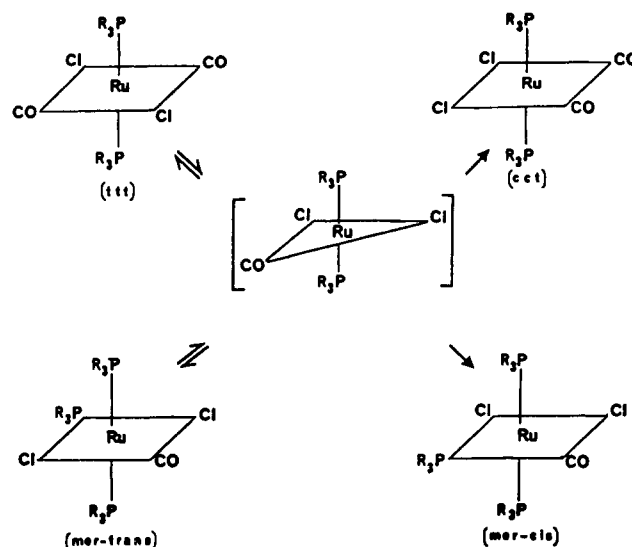

their ability to catalyze the hydrogenation and/or isomerization of allylbenzene.<sup>7c</sup>

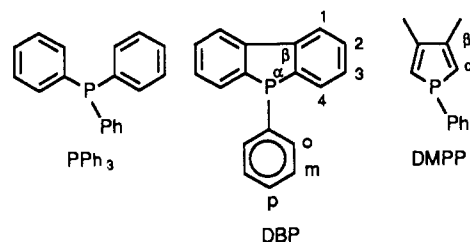

### Experimental Section

**A. Reagents and Physical Measurements.** Reagent grade chemicals were used as received or synthesized as described below. Melting points were determined on a Meltemp apparatus and are uncorrected. Elemental analyses were performed by Galbraith Laboratories, Inc., Knoxville, TN 37921.

The  $^{31}\text{P}\{^1\text{H}\}$  NMR spectra were recorded in  $\text{CDCl}_3$  at 40.26 MHz or 121.4 MHz on a JEOL FX-100 or GE GN-300 spectrometer, respectively, in the FT Mode. Phosphorus chemical shifts were measured relative to external  $\text{PPh}_3$  ( $\delta -6$  ppm) and corrected to 85%  $\text{H}_3\text{PO}_4$ . A positive sign on the phosphorus chemical shift indicates a downfield position relative to  $\text{H}_3\text{PO}_4$ . The  $^1\text{H}$  and  $^{13}\text{C}\{^1\text{H}\}$  NMR spectra were recorded in  $\text{CDCl}_3$  at 300 and 75 MHz, respectively, on a GE GN-300 NMR spectrometer in the FT mode. Infrared spectra were recorded on a Perkin-Elmer 599 spectrometer either as CsI pellets or as Nujol mulls between CsI plates. Cyclic voltammograms were recorded as previously described.<sup>8</sup>

- (1) (a) University of Nevada. (b) University of Belgrade.
- (2) Barnard, C. F. J.; Daniels, J. A.; Jeffrey, J.; Mawby, R. J. *J. Chem. Soc., Dalton Trans.* 1976, 953.
- (3) Krassowski, D. W.; Nelson, J. H.; Brower, K. R.; Hauenstein, D.; Jacobson, R. A. *Inorg. Chem.* 1988, 27, 4294.
- (4) (a) Mathey, F.; Fischer, J.; Nelson, J. H. *Struct. Bonding (Berlin)* 1983, 55, 153. (b) Affandi, S.; Nelson, J. H.; Alcock, N. W.; Howarth, D. W.; Alyea, E. C.; Sheldrick, G. M. *Organometallics* 1988, 7, 1724. (c) Attar, S. A. M.S. Thesis, University of Nevada, Reno, NV, 1987.
- (5) (a) Holah, D. G.; Hughes, A. N.; Hui, B. C.; Tse, P. K. *J. Heterocycl. Chem.* 1978, 15, 1239. (b) Mathey, F. *Chem. Rev.* 1988, 88, 429.
- (6) Krassowski, D. W.; Nelson, J. H. *J. Organomet. Chem.* 1988, 356, 93.
- (7) (a) Hallman, P. S.; Evans, D.; Osborn, J. A.; Wilkinson, G. *Chem. Commun.* 1967, 305. (b) Harmon, R. E.; Gupta, S. K.; Brown, D. J. *Chem. Rev.* 1973, 73, 21. (c) James, B. R. *Homogeneous Hydrogenation*; Wiley: New York, 1973. (d) Fahey D. R. *Catalysis in Organic Synthesis*; Academic Press: New York, 1976; p 287 ff. Halpern, J. *Pure Appl. Chem.* 1987, 59, 173. (e) Borunova, N. V.; Antonov, P. G.; Kukuskin, Yu. N.; Freidin, L. Kh.; Trink, N. O.; Ignatov, V. M.; Shirshikova, I. K. *J. Gen. Chem. USSR (Engl. Transl.)* 1980, 50, 1519.

- (8) Milosavljević, E. B.; Solujić, Lj.; Krassowski, D. W.; Nelson, J. H. *J. Organomet. Chem.* 1988, 352, 177.

Hydrogenations were carried out as previously described.<sup>6</sup> Absolute ethanol, benzene (10.0 mL each), and allylbenzene (5.0 mL) were added to 0.05 mmol of the complex in the glass high-pressure vessel. A small Teflon stirring bar was placed in the solution, the reaction mixture was purged with H<sub>2</sub> and the vessel was sealed, pressurized with H<sub>2</sub> to 100 psi, and then lowered into a constant-temperature (100 ± 0.25 °C) oil bath supported by a magnetic stirrer. The pressure was then maintained at 100 psi at 100 °C throughout the experiments. Aliquots were withdrawn periodically from the system by using a dip tube and analyzed by GLPC.

Analyses of hydrogenation reactions were made by using a Hewlett-Packard 5700A gas chromatograph equipped with a thermal conductivity detector and a 6 ft × 1/8 in. stainless steel column containing 10% carbowax 20M on 80–100 acid-washed chromosorb P. Separation of the allylbenzene, propylbenzene, and *cis*- and *trans*-β-methylstyrene was achieved by using a constant column temperature of 120 °C and a helium carrier gas flow rate of 30 mL/min. The products were identified by comparing their retention times with those of authentic samples (Aldrich): propylbenzene, 2.53 min; allylbenzene, 3.09 min; *cis*-β-methylstyrene, 3.98 min; *trans*-β-methylstyrene, 6.01 min. Peak areas were determined by using a Hewlett-Packard 3390 reporting integrator.

**B. Synthesis.** DBP,<sup>9</sup> DMPP,<sup>10</sup> *cis*-RuCl<sub>2</sub>(CO)<sub>2</sub>(PPh<sub>3</sub>)<sub>2</sub>, *trans*-RuCl<sub>2</sub>(CO)<sub>2</sub>(PPh<sub>3</sub>)<sub>2</sub>, RuCl<sub>2</sub>(PPh<sub>3</sub>)<sub>3</sub>,<sup>11</sup> RuCl<sub>2</sub>(DBP)<sub>3</sub>,<sup>4,12</sup> and [*cis*-RuCl<sub>2</sub>(CO)<sub>2</sub>(DBP)<sub>2</sub>], RuCl<sub>2</sub>(DMPP)<sub>4</sub>, *cis*-RuCl<sub>2</sub>(CO)<sub>2</sub>(DMPP)<sub>2</sub>, and *trans*-RuCl<sub>2</sub>(CO)<sub>2</sub>(DMPP)<sub>2</sub><sup>13</sup> were all synthesized according to published methods.

***trans*-RuCl<sub>2</sub>(CO)<sub>2</sub>(PPh<sub>3</sub>)<sub>2</sub> (1).** <sup>31</sup>P{<sup>1</sup>H} NMR (CDCl<sub>3</sub>): δ 16.6. <sup>13</sup>C{<sup>1</sup>H} NMR (CDCl<sub>3</sub>): δ 128.23 (t, <sup>1</sup>J<sub>PC</sub> = 9.8 Hz, C<sub>m</sub>), 130.46 (s, C<sub>p</sub>), 131.81 (t, <sup>1</sup>J<sub>PC</sub> = 47.9 Hz, C<sub>i</sub>), 134.36 (t, <sup>1</sup>J<sub>PC</sub> = 10.4 Hz, C<sub>o</sub>), 192.47 (t, <sup>2</sup>J<sub>PC</sub> = 10.4 Hz, CO) (<sup>1</sup>J<sub>PC</sub> = [<sup>1</sup>J<sub>PC</sub> + <sup>2</sup>J<sub>PC</sub>]). IR: ν<sub>CO</sub> 1998, ν<sub>RuCl</sub> 338 cm<sup>-1</sup>. Anal. Calcd for C<sub>38</sub>H<sub>30</sub>Cl<sub>2</sub>O<sub>2</sub>P<sub>2</sub>Ru: C, 60.67; H, 3.99. Found: C, 60.59; H, 4.03.

**RuCl<sub>2</sub>(DBP)<sub>2</sub>(PPh<sub>3</sub>) (2).** A slurry of RuCl<sub>2</sub>(PPh<sub>3</sub>)<sub>3</sub><sup>11</sup> (0.33 g, 3.4 × 10<sup>-4</sup> mol) and DBP (0.8 g, 0.68 mmol) was refluxed in hexane under N<sub>2</sub> overnight. The product was isolated by filtration from the hot solution: color green; yield 0.1375 g, 53.35%; dec pt 162 °C. Anal. Calcd for C<sub>54</sub>H<sub>41</sub>Cl<sub>2</sub>P<sub>3</sub>Ru: C, 67.95; H, 4.30; Cl, 7.43. Found: C, 67.90; H, 4.64; Cl, 7.43. IR: ν<sub>RuCl</sub> 334, 325 cm<sup>-1</sup>.

***mer-trans*-RuCl<sub>2</sub>(CO)(DBP)<sub>3</sub> (8).** The previously reported synthesis<sup>12</sup> of RuCl<sub>2</sub>(CO)(DBP)<sub>3</sub> produces a mixture of the *mer-cis* and *mer-trans* isomers. The pure *mer-trans* isomer is best synthesized by carbonylating a room-temperature solution of RuCl<sub>2</sub>(DBP)<sub>4</sub><sup>12</sup> in CHCl<sub>3</sub> or CH<sub>2</sub>Cl<sub>2</sub> until the solution is a clear yellow. The *mer-trans* isomer precipitates upon addition of ethanol; dec pt 251–255 °C. <sup>31</sup>P{<sup>1</sup>H} NMR (CDCl<sub>3</sub>): δ 0.87 (t), 8.35 (d, <sup>2</sup>J<sub>PP</sub> = 34.18 Hz). <sup>13</sup>C{<sup>1</sup>H} NMR (CDCl<sub>3</sub>): δ 197.57 (dt, <sup>1</sup>J<sub>PC</sub> = 91.07, <sup>2</sup>J<sub>PC</sub> = 14.28 Hz, CO). IR: ν<sub>CO</sub> 2001, ν<sub>RuCl</sub> 327 cm<sup>-1</sup>. Anal. Calcd for C<sub>55</sub>H<sub>39</sub>Cl<sub>2</sub>O<sub>3</sub>P<sub>3</sub>Ru: C, 67.37; H, 3.98. Found: C, 67.26; H, 3.78.

**[RuCl<sub>2</sub>(CO)(PPh<sub>3</sub>)<sub>2</sub>] (9).** CO was bubbled through a slurry of RuCl<sub>2</sub>(PPh<sub>3</sub>)<sub>3</sub><sup>11</sup> (0.33 g, 3.4 × 10<sup>-3</sup> mol) and at least a 6-fold excess of PPh<sub>3</sub> in toluene for just a few seconds, until the muddy brown color was replaced by a transparent light brown or red-brown. Then, N<sub>2</sub> was bubbled through to ensure the elimination of unreacted CO. The solvent was removed by using a rotary evaporator, and the remaining solid was recrystallized from CH<sub>2</sub>Cl<sub>2</sub>/EtOH to produce brown crystals: yield 0.19 g, 37%; mp 146 °C. IR: ν<sub>RuCl</sub> 318, ν<sub>CO</sub> 1960 cm<sup>-1</sup>. <sup>31</sup>P{<sup>1</sup>H} NMR: δ 43.6.

***trans*-RuCl<sub>2</sub>(CO)<sub>2</sub>(DBP)<sub>2</sub> (10).** RuCl<sub>2</sub>·3H<sub>2</sub>O (0.86 g, 3.3 mmol) was refluxed in 2-methoxyethanol with CO bubbling through until the solution become clear yellow (about 2 h). The solution was then cooled to about 30 °C and placed in a high-pressure flask. A 2:1 molar ratio of DBP (1.7 g, 6.5 mmol) was dissolved in hot CH<sub>3</sub>OCH<sub>2</sub>CH<sub>2</sub>OH, and the mixture was cooled to about 30–32 °C and added to the high-pressure vessel containing "[RuCl<sub>2</sub>(CO)<sub>2</sub>]<sub>n</sub>".<sup>15</sup> The solution was purged with CO, pressurized to 35 psi of CO, and allowed to stand overnight at ambient temperature. The product, a yellow solid, was recovered by adding H<sub>2</sub>O: yield 0.68 g, 28%; mp 198 °C. <sup>31</sup>P{<sup>1</sup>H} NMR (CDCl<sub>3</sub>): δ 15.3. <sup>13</sup>C{<sup>1</sup>H} NMR (CDCl<sub>3</sub>): δ 121.5 (s, C<sub>1</sub>), 128.0 (t, <sup>1</sup>J<sub>PC</sub> = 9.3 Hz, C<sub>3</sub>), 128.5 (t, <sup>1</sup>J<sub>PC</sub> = 10.73 Hz, C<sub>m</sub>), 130.4 (s, C<sub>p</sub>), 131.4 (s, C<sub>2</sub>), 131.6 (t, <sup>1</sup>J<sub>PC</sub>

Chart I

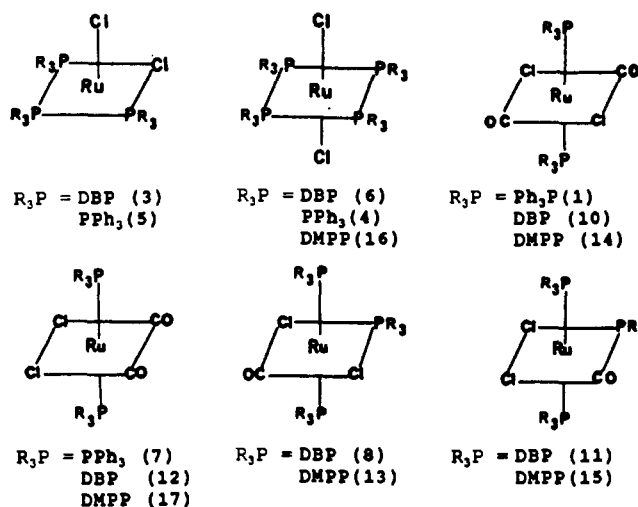

= 11.5 Hz, C<sub>4</sub>), 133.6 (t, <sup>1</sup>J<sub>PC</sub> = 11.4 Hz, C<sub>o</sub>), 134.9 (t, <sup>1</sup>J<sub>PC</sub> = 53.8 Hz, C<sub>i</sub>), 142.1 (t, <sup>1</sup>J<sub>PC</sub> = 11.0 Hz, C<sub>αβ</sub>), 193.0 (t, <sup>2</sup>J<sub>PC</sub> = 14.1 Hz, CO) (<sup>1</sup>J<sub>PC</sub> = [<sup>1</sup>J<sub>PC</sub> + <sup>2</sup>J<sub>PC</sub>]). <sup>1</sup>H NMR (CDCl<sub>3</sub>): δ 7.31 (br s, H<sub>mp</sub>, 6 H), 7.41 (t, <sup>1</sup>J<sub>PH</sub> = 1.9 Hz, H<sub>3</sub>, 4 H), 7.55 (t, <sup>1</sup>J<sub>PH</sub> = 2.04 Hz, H<sub>2</sub>, 4 H), 7.84 (t, <sup>1</sup>J<sub>PH</sub> = 1.44 Hz, H<sub>o</sub>, 4 H), 7.90 (d, <sup>1</sup>J<sub>PH</sub> = 1.96 Hz, H<sub>4</sub>, 4 H), 8.28 (m, H<sub>1</sub>, 4 H) (<sup>1</sup>J<sub>PH</sub> = [<sup>1</sup>J<sub>PH</sub> + <sup>2</sup>J<sub>PH</sub>]). IR (Nujol): ν<sub>CO</sub> 2013, ν<sub>RuCl</sub> 335 cm<sup>-1</sup>. Anal. Calcd for C<sub>38</sub>H<sub>26</sub>Cl<sub>2</sub>P<sub>2</sub>O<sub>2</sub>Ru: C, 60.99; H, 3.47. Found: C, 60.63; H, 3.62.

***trans*-RuCl<sub>2</sub>(CO)<sub>2</sub>(DMPP)<sub>2</sub> (14).** This was prepared in the same manner as *trans*-RuCl<sub>2</sub>(CO)<sub>2</sub>(DBP)<sub>2</sub>, except that the yellow solution was cooled to 0 °C, the ligand was added directly to the reaction solution in the high-pressure vessel, and the vessel was submerged in an ice bath overnight. Product that did not crystallize out overnight was recovered by the addition of H<sub>2</sub>O. Orange crystals or a yellow powder was produced: yield 0.37 g, 36%; mp 164 °C. <sup>31</sup>P{<sup>1</sup>H} NMR (CDCl<sub>3</sub>): δ 27.4. <sup>13</sup>C{<sup>1</sup>H} NMR (CDCl<sub>3</sub>): δ 17.5 (t, <sup>1</sup>J<sub>PC</sub> = 11.72 Hz, CH<sub>3</sub>), 125.0 (t, <sup>1</sup>J<sub>PC</sub> = 49.82 Hz, C<sub>β</sub>), 128.6 (t, <sup>1</sup>J<sub>PC</sub> = 10.2 Hz, C<sub>m</sub>), 130.2 (s, C<sub>p</sub>), 131.0 (t, <sup>1</sup>J<sub>PC</sub> = 10.3 Hz, C<sub>o</sub>), 131.4 (t, <sup>1</sup>J<sub>PC</sub> = 46.8 Hz, C<sub>i</sub>), 150.9 (t, <sup>1</sup>J<sub>PC</sub> = 11.7 Hz, C<sub>α</sub>), 193.1 (t, <sup>2</sup>J<sub>PC</sub> = 13.2 Hz, CO). <sup>1</sup>H NMR (CDCl<sub>3</sub>): δ 2.10 (s, CH<sub>3</sub>, 12 H), 6.89 (d, <sup>1</sup>J<sub>PH</sub> = 32.2 Hz, H<sub>o</sub>, 4 H), 7.3–7.9 (m, Ar H, 10 H). IR: ν<sub>CO</sub> 2004, ν<sub>RuCl</sub> 327 cm<sup>-1</sup>. Anal. Calcd for C<sub>26</sub>H<sub>26</sub>Cl<sub>2</sub>O<sub>2</sub>P<sub>2</sub>Ru: C, 51.69; H, 4.30. Found: C, 51.53; H, 4.18.

***mer-cis*-RuCl<sub>2</sub>(CO)L<sub>3</sub>.** A solution of *mer-trans*-RuCl<sub>2</sub>(CO)L<sub>3</sub> in *sym*-tetrachloroethane was refluxed overnight. The solvent was removed by vacuum and the product recrystallized from dichloromethane/ethanol. The desired products were recovered in near quantitative yields.

***mer-cis*-RuCl<sub>2</sub>(CO)(DBP)<sub>3</sub> (11).** Yellow crystals were produced; dec pt 260–268 °C. <sup>31</sup>P{<sup>1</sup>H} NMR (CDCl<sub>3</sub>): δ 12.9 (d), 30.9 (t, <sup>2</sup>J<sub>PP</sub> = 24.5 Hz). <sup>13</sup>C{<sup>1</sup>H} NMR: δ 199.6 (dt, <sup>1</sup>J<sub>PC</sub> = 14.4, <sup>2</sup>J<sub>PC</sub> = 12.0 Hz, CO). IR: ν<sub>CO</sub> 1964, ν<sub>RuCl</sub> 309, 284 cm<sup>-1</sup>. Anal. Calcd for C<sub>55</sub>H<sub>39</sub>Cl<sub>2</sub>O<sub>3</sub>P<sub>3</sub>Ru: C, 67.37; H, 3.98. Found: C, 67.35; H, 3.82.

***mer-cis*-RuCl<sub>2</sub>(CO)(DMPP)<sub>3</sub> (15).** Pale orange crystals or yellow powder was formed; mp 270 °C. <sup>31</sup>P{<sup>1</sup>H} NMR (CDCl<sub>3</sub>): δ 25.48 (d), 39.60 (t, <sup>2</sup>J<sub>PP</sub> = 27.8 Hz). <sup>13</sup>C{<sup>1</sup>H} NMR (CDCl<sub>3</sub>): for the mutually *trans* phospholes, δ 17.6 (t, <sup>1</sup>J<sub>PC</sub> = 12.6 Hz, CH<sub>3</sub>), 125.6 (t, <sup>1</sup>J<sub>PC</sub> = 49.2 Hz, C<sub>α,1</sub>), 126.4 (t, <sup>1</sup>J<sub>PC</sub> = 49.3 Hz, C<sub>α,2</sub>), 127.6 (t, <sup>1</sup>J<sub>PC</sub> = 9.0 Hz, C<sub>m</sub>), 129.4 (d, <sup>1</sup>J<sub>PC</sub> = 1.9 Hz, C<sub>p</sub>), 130.6 (t, <sup>1</sup>J<sub>PC</sub> = 43.2 Hz, C<sub>i</sub>), 132.4 (t, <sup>1</sup>J<sub>PC</sub> = 9.3 Hz, C<sub>o</sub>), 150.3 (t, <sup>1</sup>J<sub>PC</sub> = 11.1 Hz, C<sub>β,1</sub>), 151.0 (t, <sup>1</sup>J<sub>PC</sub> = 11.3 Hz, C<sub>β,2</sub>); for the phosphole *trans* to chloride, δ 17.7 (d, <sup>3</sup>J<sub>PC</sub> = 8.1 Hz, CH<sub>3</sub>), 128.6 (d, <sup>3</sup>J<sub>PC</sub> = 9.9 Hz, C<sub>m</sub>), 129.2 (d, <sup>1</sup>J<sub>PC</sub> = 50.6 Hz, C<sub>α</sub>), 129.4 (s, C<sub>p</sub>), 131.6 (d, <sup>2</sup>J<sub>PC</sub> = 9.1 Hz, C<sub>o</sub>), 135.2 (dt, <sup>1</sup>J<sub>PC</sub> = 46.3, <sup>3</sup>J<sub>PC</sub> = 3.1 Hz, C<sub>i</sub>), 149.8 (d, <sup>2</sup>J<sub>PC</sub> = 9.4 Hz, C<sub>α</sub>), 197.6 (td, <sup>1</sup>J<sub>PC</sub> = 13.3, <sup>2</sup>J<sub>PC</sub> = 3.1 Hz, CO). <sup>1</sup>H NMR (CDCl<sub>3</sub>): for the mutually *trans* phospholes, δ 1.93 (s, CH<sub>3</sub>, 12 H), 6.27 (t, <sup>1</sup>J<sub>PH</sub> = 30.3 Hz, H<sub>α,1</sub>, 2 H), 6.34 (t, <sup>1</sup>J<sub>PH</sub> = 30.6 Hz, H<sub>α,2</sub>, 2 H), 7.0–8.1 (m, Ar H, 15 H); for the phosphole *trans* to chloride, δ 2.02 (s, CH<sub>3</sub>, 6 H), 6.54 (d, <sup>2</sup>J<sub>PH</sub> = 32.1 Hz, H<sub>o</sub>, 2 H). IR: ν<sub>CO</sub> 1953, ν<sub>RuCl</sub> 278, 296 cm<sup>-1</sup>. Anal. Calcd for C<sub>37</sub>H<sub>39</sub>Cl<sub>2</sub>O<sub>3</sub>P<sub>3</sub>Ru: C, 58.14; H, 5.10. Found: C, 57.74; H, 5.11.

## Results and Discussion

**Synthesis.** In order to study the effects of geometry and the nature of the phosphine on catalytic activity, the series of compounds shown in Chart I was synthesized. In addition a chloride-bridged dimer, [RuCl<sub>2</sub>(CO)(PPh<sub>3</sub>)<sub>2</sub>]<sub>2</sub> (9), and a mixed phosphine complex, RuCl<sub>2</sub>(DBP)<sub>2</sub>(PPh<sub>3</sub>) (2) were prepared.

RuCl<sub>2</sub>L<sub>3</sub> (L = PPh<sub>3</sub>,<sup>11</sup> DBP,<sup>12</sup> DMPP<sup>13</sup>) have been reported previously. For 3 and 6, the literature<sup>12</sup> methods of synthesis were

- Affandi, S.; Green, R. L.; Hsieh, B. T.; Holt, M. S.; Nelson, J. H.; Alyea, E. C. *Synth. React. Inorg. Met.-Org. Chem.* **1987**, *17*, 307.
- Breque, A.; Mathey, F.; Savignac, P. *Synthesis* **1981**, 983.
- Stephenson, T. A.; Wilkinson, G. *J. Inorg. Nucl. Chem.* **1966**, *28*, 945.
- Holah, D. G.; Hughes, A. N.; Hui, B. C.; Krupa, N.; Wright, K. *Phosphorus Relat. Group V Elem.* **1975**, *5*, 145.
- Wilkes, L. M.; Nelson, J. H.; McCusker, L. B.; Seff, K.; Mathey, F. *Inorg. Chem.* **1983**, *22*, 2476.
- Ruiz-Ramirez, L.; Stephenson, T. A. *J. Chem. Soc., Dalton Trans.* **1974**, 1640.
- (a) Seddon, E. A.; Seddon, K. R. *The Chemistry of Ruthenium*; Elsevier: Amsterdam, 1984. (b) Thomas, N. C. *Coord. Chem. Rev.* **1986**, *70*, 121.

used, but we found that **3** was a brown product with  $\nu_{\text{RuCl}}$  at 309 and 240  $\text{cm}^{-1}$ , not the reported salmon-colored compound with  $\nu_{\text{RuCl}}$  at 327 and 272  $\text{cm}^{-1}$ . *mer-trans*- $\text{RuCl}_2(\text{CO})\text{L}_3$  were synthesized according to the literature method for  $\text{L} = \text{DMPP}$ ,<sup>11</sup> but for  $\text{L} = \text{DBP}$ , the literature method<sup>12</sup> produced a mixture of the *mer-cis* ( $\nu_{\text{CO}}$  1964  $\text{cm}^{-1}$ ) and *mer-trans* ( $\nu_{\text{CO}}$  2001  $\text{cm}^{-1}$ ) isomers. The pure *mer-trans* isomer is best synthesized by bubbling CO through a chloroform or dichloromethane solution of **6**. The *mer-cis* isomers of both compounds can be synthesized by refluxing a *sym*-tetrachloroethane solution of the *mer-trans* isomers.<sup>3</sup>

There are several reported methods<sup>14,16</sup> for the synthesis of  $\text{RuCl}_2(\text{CO})(\text{PPh}_3)_3$ . Our attempts to duplicate each method proved unsuccessful leading always to impure  $\text{RuCl}_2(\text{CO})_2(\text{PPh}_3)_2$ . Roper<sup>17</sup> has suggested that the instability of *mer-trans*- $\text{RuCl}_2(\text{CO})(\text{PPh}_3)_3$  relative to the reported<sup>18</sup> *mer-cis*- $\text{RuHCl}(\text{CO})(\text{PPh}_3)_3$  is due to the greater trans influence of hydride than CO, which lengthens the trans Ru-P bond and thus reduces steric crowding. The  $\text{PPh}_3$  trans to hydride is weakly bound and readily substituted by a variety of neutral ligands.<sup>19</sup> The <sup>31</sup>P NMR data<sup>16b</sup> and IR data reported for *mer-trans*- $\text{RuCl}_2(\text{CO})(\text{PPh}_3)_3$  are clearly those for a mixture of products or isomers, including the dimer **9**. This dimer was synthesized as a single isomer, as opposed to an isomeric mixture,<sup>14</sup> by bubbling CO very briefly (a few seconds too long will produce **7**) through a toluene solution of **5** containing a 6:1 molar ratio of  $\text{PPh}_3$ . The solution was then purged with  $\text{N}_2$ , the solvent removed under vacuum at ambient temperature, and the product crystallized from  $\text{CH}_2\text{Cl}_2/\text{EtOH}$ .

Compounds **1**,<sup>11</sup> **7**,<sup>20</sup> and **12**,<sup>13</sup> **13**,<sup>13</sup> and **17**<sup>13</sup> were synthesized by literature methods. The yields of the *cis*- $\text{RuCl}_2(\text{CO})_2(\text{R}_3\text{P})_2$  complexes **7**, **12**, and **17** were considerably improved by adding the ligand to  $[\text{Ru}(\text{CO})_2\text{Cl}_2]_2$  solutions under a 35-psi CO pressure.

The established methods<sup>3,13</sup> for synthesis of  $\text{RuCl}_2(\text{CO})_2(\text{PR}_3)_2$  complexes yielded  $\text{RuCl}_2(\text{CO})(\text{PR}_3)_3$  when  $\text{R}_3\text{P}$  was DBP or DMPP. This was true for DBP even when the ligand to metal molar ratio was less than 2 to 1. For both DBP and DMPP there are two driving forces that promote the formation of  $\text{RuCl}_2(\text{CO})(\text{PR}_3)_3$  complexes. These are the small size of these ligands<sup>3</sup> and  $\pi$ -electron overlap made possible by the face-to-face configuration of the phosphole moiety in the tris(phosphole) compound.

This face-to-face overlap can be seen clearly in the X-ray crystal structure of a related compound *mer*- $\text{Cr}(\text{CO})_3(\text{DBP})_3$ .<sup>4b</sup> In the Cr compound, the distance between the phosphole planes, 3.4 Å, approximates the van der Waals distance. Similar face-to-face phosphole overlap is also reported for Ni(II) complexes of 1-methyl- and 1-ethylidibenzophosphole.<sup>21</sup>

Compounds **10** and **14** could not be synthesized by published methods. For **14**, " $\text{RuCl}_3 \cdot 3\text{H}_2\text{O}$ " was carbonylated in refluxing 2-methoxyethanol until the solution became clear yellow. The solution was then cooled to 0 °C. A 2:1 molar ratio of DMPP was added to the cooled solution, and it was placed in a high-pressure vessel. The solution was purged with CO and then pressurized to 35 psi of CO. Stirring the solution overnight produced a yellow powder. If the solution were stirred for less than 1 h and then left undisturbed overnight, orange crystals of **14** were recovered the next day. Second and third fractions of **14** could be recovered upon the addition of water, but subsequent fractions were mixtures of  $\text{RuCl}_2(\text{CO})_2(\text{DMPP})_2$  and  $\text{RuCl}_2(\text{CO})(\text{DMPP})_3$ .

The foregoing procedure was not applicable to the DBP analogue, as DPB is a solid whereas DMPP is a liquid. When DBP was first dissolved in  $\text{CHCl}_3$  or  $\text{CH}_2\text{Cl}_2$  before addition to the

$[\text{RuCl}_2(\text{CO})_2]_n$  solution, no matter how small the amount of halocarbon solvent used, the product was always the *cis* isomer **12**. The ligand is sparingly soluble in cold alcohol and rapidly precipitates from a cool reaction mixture, but heat drives the reaction to the formation of the thermodynamically favored **12**. The ideal temperature to maintain the ligand in solution but inhibit isomerization was found to be 30–35 °C. For this reaction, DBP was dissolved in hot alcohol, and the ligand and ruthenium solutions were allowed to cool to 30–35 °C before being combined and pressurized as in the synthesis of **14**. The product **10** was recovered by the addition of water.

Mixed-ligand complexes of the type  $\text{RuCl}_2\text{L}_n\text{L}'_m$  ( $\text{L} = \text{PPh}_3$ ,  $\text{L}' = \text{DBP}$ ) were synthesized by ligand-substitution reactions (vide infra).

**Characterization. Infrared Data.** The IR data in the CO and Ru-Cl regions (see Experimental Section) are consistent with the assigned structures.

**<sup>31</sup>P NMR Data.** The <sup>31</sup>P NMR data for **4**,<sup>22</sup> **5**,<sup>22</sup> and **12**,<sup>13</sup> **13**,<sup>13</sup> **16**,<sup>13</sup> and **17**<sup>13</sup> agreed with the literature. Compounds **1**, **6**, **7**, **9**, **10**, **12**, **14**, **16**, and **17** all show single <sup>31</sup>P resonances as expected for symmetry-related phosphines in chemically equivalent environments.

For compounds **8** and **11**, *mer-trans* and *mer-cis* isomers of  $\text{RuCl}_2(\text{CO})(\text{DBP})_3$ , the expected doublet for the two mutually trans phosphorus nuclei and a triplet for the unique phosphorus are observed. As in previous work in our laboratory,<sup>13</sup> the triplet for the unique phosphorus is upfield of the doublet for the *mer-trans* isomer and downfield for the *mer-cis* isomer. In the *mer-trans* isomer, the unique phosphine is trans to CO; in the *mer-cis* isomer, it is trans to Cl. These data are consistent with a relative trans influence of  $\text{CO} > \text{P} > \text{Cl}$ . Shaw<sup>23</sup> and co-workers, however, report a relative trans influence of  $\text{P} > \text{CO} > \text{Cl}$  for ruthenium(II) phosphines. The <sup>31</sup>P NMR spectrum of compound **15** also shows a first-order triplet (39.6 ppm) and doublet (25.5 ppm). For compound **13**, because  $\Delta\delta(\text{AB})/J_{\text{PP}} < 15$ , all eight major lines characteristic of an  $\text{AB}_2$  spectrum are observed. Analysis of the second-order multiplet gives chemical shifts of 19.89 ppm for the unique phosphines and 26.65 ppm for the two mutually trans phosphines;  $J_{\text{AB}} = 35.89$  Hz, consistent with typical coupling constants for *cis* phosphorus nuclei in ruthenium(II) compounds.<sup>24</sup>

Compounds **2**, **3**, and **6** were analyzed by using variable-temperature 40.26- and 121.4-MHz <sup>31</sup>P NMR spectroscopy. For low-temperature spectra, the compounds were dissolved in  $\text{CH}_2\text{Cl}_2/\text{toluene}-d_8$  at -70 °C and spectra were taken stepwise at increasing increments of 20 °C. This procedure was necessary to preserve the integrity of compounds **2** and **3**, which decompose rapidly in solution at room temperature. For compound **6**, the chemical shift remains 6.1 ppm throughout the temperature range of -70 to +30 °C, indicating that this is a true chemical shift and not just an average resonance resulting from rapidly exchanging nuclei. Thus, compound **6** has the trans geometry.

At 30 °C the spectrum of **3** shows a singlet at 34.27 ppm and a broad, unresolved multiplet downfield of the singlet. At -70 °C, two poorly resolved resonances, one with the overall shape of a triplet at 45.7 ppm and the second with the approximate shape of a doublet at 38.3 ppm,  $^2J_{\text{PP}} \approx 35$  Hz (integration 1:2), can be seen. This is the same  $\text{A}_2\text{X}$  pattern observed for **5**,<sup>22</sup> and consistent with the X-ray crystal structure<sup>25</sup> of **5**, we have assigned a square-based pyramidal structure to compound **3**. Unlike those of **5**,<sup>22</sup> solutions of **3** did not show the AB pattern that is consistent<sup>22</sup> with the presence of the dimer  $[\text{RuCl}_2\text{L}_2]_2$ .

At 30 °C the NMR spectrum of **2** shows two narrow singlets at 32.76 and 28.09 ppm, indicating rapid exchange. At -30 °C, there was evidence in the spectrum for three compounds plus free triphenylphosphine. The major species, an ABX system, gave a triplet ( $\delta$  55.4 ppm,  $J_{\text{AX}} = J_{\text{BX}} = 30$  Hz) and an AB quartet ( $\delta_{\text{A}}$

(16) (a) Svoboda, P.; Belopotapova, T. S.; Hetflejs, J. *J. Organomet. Chem.* **1974**, *65*, C37. (b) Halpern, J.; James, B. R.; Kemp, A. L. W. *J. Am. Chem. Soc.* **1966**, *88*, 5142.

(17) Roper, W. R. Personal communication.

(18) Vaska, L.; Diluzio, J. W. *J. Am. Chem. Soc.* **1961**, *83*, 1262. Levinson, J. J.; Robinson, S. D. *J. Chem. Soc. A* **1970**, 2947.

(19) Reference 15a, pp 666–667.

(20) James, B. R.; Markham, L. D.; Hui, B. C.; Rempel, G. L. *J. Chem. Soc., Dalton Trans.* **1973**, 2247.

(21) Holah, D. G.; Hughes, A.; Wright, K. *Coord. Chem. Rev.* **1975**, *15*, 239 and references therein.

(22) Armit, P. W.; Boyd, A. S. F.; Stephenson, T. A. *J. Chem. Soc., Dalton Trans.* **1975**, 1663.

(23) Jenkins, J. M.; Lupin, M. S.; Shaw, B. L. *J. Chem. Soc. A* **1966**, 1787.

(24) Verkade, J. G. *Coord. Chem. Rev.* **1972**/73, *9*, 1. Pankowski, M.; Chodkiewicz, W.; Simmonin, M. *Inorg. Chem.* **1985**, *24*, 533.

(25) LaPlaca, S. J.; Ibers, J. A. *Inorg. Chem.* **1965**, *4*, 778.

21.0 ppm,  $\delta_B$  17.71 ppm,  $J_{AB} = 336.78$  Hz). Consistent with the large  $J_{AB}$  coupling constant characteristic of trans phosphines,<sup>24</sup> and the small value for  $J_{AX} = J_{BX}$ , which is characteristic of cis phosphine coupling constants,<sup>24</sup> as well as the existence of three separate chemical shifts, we have assigned the structure shown below to **2**. Reaction conditions as well as <sup>31</sup>P NMR data suggest

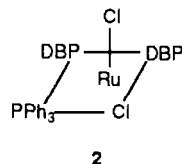

that the compound is the one shown and not  $\text{RuCl}_2(\text{DBP})(\text{PPh}_3)_2$ . In the synthesis of **2**, 2 mol of DBP were added to 1 mol of **5**. The product was isolated from the hot reaction mixture, and the NMR spectrum of the filtrate shows the presence of  $\text{PPh}_3$  ( $\delta$  -6 ppm) but no free DBP ( $\delta$  -11 ppm), suggesting that all of the DBP is consumed in the reaction. Additional evidence of DBP's ability to replace  $\text{PPh}_3$  in the ruthenium(II) coordination sphere was obtained from the reaction of a 4:1 molar ratio of DBP with **5** in refluxing hexane. In this case, DBP completely replaced the  $\text{PPh}_3$  to form **6**. In the reverse reaction, a 4:1 molar ratio of  $\text{PPh}_3$  to **3** or **6** causes only partial replacement of DBP to form a mixture of mixed-ligand products.

There is evidence for two other minor products in the -30 °C NMR spectrum of **2**. A broad multiplet near 28 ppm cannot be unambiguously assigned. Two doublets appearing at 62.7 and approximately 55.5 ppm (overlapping the triplet chemical shift at 55.4 ppm) ( $J_{AX} = 48.6$  Hz) are consistent with the dimeric  $[\text{RuCl}_2(\text{PPh}_3)_2]_2$  observed<sup>22</sup> for  $\text{RuCl}_2(\text{PPh}_3)_3$  in solution. The spectrum also contains three very weak singlets at 32, 37.4, and 61.3 ppm unresolved at -70 °C. Hence,  $\text{RuCl}_2(\text{DBP})_2(\text{PPh}_3)$  undergoes extensive ligand dissociation in solution.

**<sup>13</sup>C and <sup>1</sup>H NMR Data.** Consistent with previous research in our laboratory,<sup>3,26</sup> the carbon and proton nuclei of mutually trans phosphines (as in compounds **1**, **7**, **12**–**15**, and **17**) appear as pseudotriplets in their NMR spectra. The coupling constants (separation between the outer two lines of these pseudotriplets) are equal to  $|^nJ_{PX} + ^{n+2}J_{PX}|$ . Extensive overlap in the spectra of **8** and **11** prevent the unambiguous assignment of all but the carbonyl carbons. These appear as doublets of triplets consistent with the assigned geometries.

No symmetry element relates the  $\alpha$ - or  $\beta$ -carbons of the mutually trans phospholes in **15**, and as a result both give rise to two chemical shifts. In contrast, for the mutually trans phospholes of **13** the  $\alpha$ - and  $\beta$ -carbons are related by a mirror plane and are chemical shift equivalent. Thus, the infrared and NMR data support the assigned structures.

**Geometrical Isomerization and Ligand-Redistribution Reactions.** Ligand-redistribution and isomerization reactions were carried out in *sym*-tetrachloroethane and monitored by <sup>31</sup>P NMR spectroscopy.

**A. Carbonyl-Containing Compounds.** Trans to cis geometrical isomerization for ruthenium(II) carbonyl compounds of the type  $\text{RuCl}_2(\text{CO})_2(\text{PR}_3)_2$  and  $\text{RuCl}_2(\text{CO})(\text{PR}_3)_3$  via a 5-coordinate intermediate have been well established.<sup>3,13,27</sup> Compounds **1**, **8**, and **13** isomerize in the expected manner. In this study, however, we found that the solution behavior of the  $\text{RuCl}_2(\text{CO})_2(\text{phosphole})_2$  complexes differed markedly from that of the analogous phosphine complexes. In the first place, isomerization of *mer-trans*- $\text{RuCl}_2(\text{CO})(\text{R}_3\text{P})_3$  is generally faster<sup>3</sup> than isomerization of *ttt*- $\text{RuCl}_2(\text{CO})_2(\text{R}_3\text{P})_2$ . For the phosphole complexes, the opposite is true. Furthermore, **10** and **14** do not undergo simple *ttt* to *cct* isomerization, but undergo thermally induced ligand redistribution reactions as well to form  $\text{RuCl}_2(\text{CO})(\text{phosphole})_3$  and a phosphole-deficient compound. The products and their ratios

are dependent upon the temperature of the reaction and the nature of the phosphole. Although ligand-redistribution reactions have been reported<sup>28,29</sup> for other transition metals, there are few examples<sup>30</sup> of ligand-redistribution reactions of ruthenium(II) complexes.

Compound **14** was stable in solution overnight at temperatures below 55 °C. At 60 °C, the major product was *cct*- $\text{RuCl}_2(\text{CO})_2(\text{DMPP})_2$  ( $\delta(^{31}\text{P})$  33.60, 23.34 ppm;  $^2J_{PP} = 30.5$  Hz). At this temperature, the all-cis compound is stable in solution for at least 48 h. The all-cis structure places the two phosphole ligands cis, allowing the same face-to-face overlap that is present<sup>13</sup> in the tris(phosphole) complex. *cct*- $\text{RuCl}_2(\text{CO})_2(\text{DMPP})_2$ , the expected product based on previously observed geometric isomerization reactions<sup>3,27</sup> of *ttt*- $\text{RuCl}_2(\text{CO})_2(\text{PR}_3)_2$ , was also produced in this reaction. Compound **14** also underwent significant ligand redistribution to form both isomers of  $\text{RuCl}_2(\text{CO})(\text{DMPP})_3$ . At higher temperatures (up to 80 °C), the same mixture of products (**17**, **15**, **13**, and the all-cis complex) persists, but the reactions take place faster and the amount of **17** increases, while the amounts of **15** and **13** decrease.

For compound **10** ligand redistribution to form  $\text{RuCl}_2(\text{CO})(\text{DBP})_3$  can be observed at temperatures as low as 30 °C. In addition, a previously unidentified product ( $\delta(^{31}\text{P})$  3.6 ppm) was observed. We thought this might be the dimer,  $[\text{RuCl}_2(\text{CO})(\text{DBP})_2]_2$ . However, two mono(phosphine)tricarbonylruthenium(II) compounds  $\text{RuCl}_2(\text{CO})(\text{R}_3\text{P})$  have been reported ( $\text{R}_3\text{P} = \text{PPh}_3$ <sup>31</sup> and  $\text{Ph}_2\text{PCH}_2\text{CH}_2\text{SPh}$ <sup>32</sup>). Neither compound has been characterized by <sup>31</sup>P NMR spectroscopy, so a comparison of NMR chemical shifts could not be made. The  $\nu_{\text{CO}}$  vibrations reported (2130, 2056, 1995  $\text{cm}^{-1}$ ) overlap the region of the IR spectrum where the CO vibrations from the other ligand-redistribution and isomerization products appear, so unambiguous assignment is not possible.

Ligand-redistribution and isomerization reactions also take place under catalytic conditions ( $T = 100$  °C,  $P = 100$  psi of  $\text{H}_2$ ) even for compounds<sup>6</sup> such as **7** and **11** that are thermally stable at temperatures up to 147 °C under noncatalytic conditions. A mixture of products is recovered from the catalytic solution, none of which is a hydride by <sup>1</sup>H NMR spectroscopy and some of which are unidentifiable. This supports the suggestion<sup>3,6</sup> that the mechanism for loss of ligand under catalytic conditions might be different from that which obtains under isomerization conditions.

**B. Ligand-Substitution Reactions for  $\text{RuCl}_2\text{Cl}_3$ .** When  $\text{RuCl}_2(\text{PPh}_3)_3$  is refluxed in hexane under nitrogen overnight with DBP, ligand-exchange reactions take place whose products depend on the molar ratio of the starting material and the incoming phosphole. When the ratio is 1:4, a green solution is first seen, but the reaction mixture eventually takes on the salmon color of  $\text{RuCl}_2(\text{DBP})_4$ .  $\text{RuCl}_2(\text{DBP})_4$  can be isolated from the hot solution. The green intermediate<sup>33</sup> is probably  $\text{RuCl}_2\text{L}_n\text{L}'_m(\text{solvent})$ . With a 1:1 molar ratio, a light brown product, unidentifiable by <sup>31</sup>P NMR spectroscopy because ligand exchange is rapid even at very low temperatures, precipitates. With a 1:2 molar ratio of  $\text{RuCl}_2(\text{PPh}_3)_3$  to DBP  $\text{RuCl}_2(\text{DBP})_2(\text{PPh}_3)$  was formed. The green color of this product is probably due to coordinated solvent.<sup>33</sup> In the reverse reaction,  $\text{RuCl}_2(\text{DBP})_4$  reacts with  $\text{PPh}_3$  (1:4 molar ratio) to produce a light brown mixture of products. We have previously shown<sup>13</sup> that DMPP will completely replace  $\text{PPh}_3$  in  $\text{RuCl}_2(\text{PPh}_3)_4$ , demonstrating that DBP and DMPP are both better donors than  $\text{PPh}_3$  toward ruthenium(II).

**Catalysis.** Each ruthenium(II) complex was tested for catalytic activity toward the hydrogenation of allylbenzene to propylbenzene

(26) Redfield, D. A.; Nelson, J. H.; Cary, L. W. *Inorg. Nucl. Chem. Lett.* **1974**, *10*, 727.  
 (27) Barnard, C. F. J.; Daniels, J. A.; Jeffrey, J.; Mawby, R. J. *J. Chem. Soc., Dalton Trans.* **1976**, 953.

(28) Garrou, P. E. *Adv. Organomet. Chem.* **1984**, *23*, 95.  
 (29) (a) Rahn, J. A.; Holt, M. S.; Nelson, J. H. *Polyhedron* **1989**, *8*, 897.  
 (b) Verystuyft, A. W.; Nelson, J. H. *Synth. React. Inorg. Met.-Org. Chem.* **1975**, *5*, 69. (c) Verystuyft, A. W.; Redfield, D. A.; Cary, L. W.; Nelson, J. H. *Inorg. Chem.* **1976**, *15*, 1128.  
 (30) Armit, P. W.; Sime, W. J.; Stephenson, T. A. *J. Chem. Soc., Dalton Trans.* **1976**, 2121.  
 (31) Johnson, B. F. G.; Johnston, R. D.; Lewis, J. J. *J. Chem. Soc. A* **1969**, 792.  
 (32) Sanger, A. R.; Day, R. W. *Inorg. Chim. Acta* **1982**, *62*, 99.  
 (33) Chaudret, B. N.; Cole-Hamilton, D. J.; Wilkinson, G. *J. Chem. Soc., Dalton Trans.* **1978**, 1739.

Table I. Catalytic Efficiency of Ruthenium(II) Phosphole and Phosphine Complexes

catalyst	turnover numbers <sup>a</sup>			$T_f$ , <sup>b</sup> h	% propylbenzene at $T_f$
	loss of allylbenzene	formation of <i>trans</i> - $\beta$ -methylstyrene	formation of propylbenzene		
<i>ttt</i> -RuCl <sub>2</sub> (CO) <sub>2</sub> (PPh <sub>3</sub> ) <sub>2</sub> (1)	2117	1255	406	0.40	21.71
RuCl <sub>2</sub> (DBP) <sub>2</sub> (PPh <sub>3</sub> ) (2)	1642	659	832	0.42	52.73
RuCl <sub>2</sub> (DBP) <sub>3</sub> (3)	1584	822	744	0.47	48.32
RuCl <sub>2</sub> (PPh <sub>3</sub> ) <sub>4</sub> (4)	1501	786	688	0.48	47.18
RuCl <sub>2</sub> (PPh <sub>3</sub> ) <sub>3</sub> (5)	1432	884	482	0.52	35.20
<i>t</i> -RuCl <sub>2</sub> (DBP) <sub>4</sub> (6)	1429	546	768	0.58	60.39
<i>cct</i> -RuCl <sub>2</sub> (CO) <sub>2</sub> (PPh <sub>3</sub> ) <sub>2</sub> (7)	1089	649	305	0.67	27.69
<i>mt</i> -RuCl <sub>2</sub> (CO)(DBP) <sub>3</sub> (8)	1042	761	211	0.70	20.71
[RuCl <sub>2</sub> (CO)(PPh <sub>3</sub> ) <sub>2</sub> ] <sub>2</sub> (9)	916	700	86	0.84	8.42
<i>ttt</i> -RuCl <sub>2</sub> (CO) <sub>2</sub> (DBP) <sub>2</sub> (10)	712	523	141	1.02	23.02
<i>mc</i> -RuCl <sub>2</sub> (CO)(DBP) <sub>3</sub> (11)	689	514	133	1.08	20.07
<i>cct</i> -RuCl <sub>2</sub> (CO) <sub>2</sub> (DBP) <sub>2</sub> (12)	375	269	73	1.46	18.80
<i>mt</i> -RuCl <sub>2</sub> (CO)(DMPP) <sub>3</sub> (13)	157	132	17	NA	
<i>ttt</i> -RuCl <sub>2</sub> (CO) <sub>2</sub> (DMPP) <sub>2</sub> (14)	136	69	14	NA	
<i>mc</i> -RuCl <sub>2</sub> (CO)(DMPP) <sub>3</sub> (15)	130	103	23	NA	
<i>t</i> -RuCl <sub>2</sub> (DMPP) <sub>4</sub> (16)	110	60	42	NA	
<i>cct</i> -RuCl <sub>2</sub> (CO) <sub>2</sub> (DMPP) <sub>2</sub> (17)	96	77	3	NA	

<sup>a</sup> In moles of substrate per mole of Ru per hour. <sup>b</sup> Time required for loss of at least 90% of starting material. For compound 9,  $T_f$  represents the time at which 11.5% of the starting material remained. NA is not applicable.

and the isomerization of allylbenzene to *cis*- and *trans*- $\beta$ -methylstyrene. The catalyst (0.05 mmol), allylbenzene (5 mL) (catalyst to substrate 1:965) and absolute ethanol and thiophene-free benzene (10 mL each) were placed in a high-pressure vessel with a magnetic stirring bar. The solution was purged with H<sub>2</sub> and then sealed and placed in a constant-temperature bath supported by a magnetic stirrer. The temperature (100 °C) and pressure (100 psi of H<sub>2</sub>) were maintained constant throughout the reactions. Aliquots of the reaction mixture were removed periodically, and the amounts of the various hydrocarbons were measured by gas chromatography.

Hydrogenation reactions using catalysts synthesized from DBP or PPh<sub>3</sub> were observed until 0–10% of the starting materials remained. All of these reactions were complete in less than 2 h. By comparison, all catalytic reactions involving compounds made with DMPP were slow. These reactions were not followed to completion, but only for 3–6 h. This seemingly arbitrary cutoff point was chosen because the high-pressure vessels occasionally shattered under reaction conditions; this did not occur if the reaction times were limited to 6 h or less.

Table I lists the catalysts and the turnover numbers in moles of substrate per mole of ruthenium per hour for the loss of starting material, for hydrogenation of the starting material to propylbenzene, and for isomerization of allylbenzene to *cis*- and *trans*- $\beta$ -methylstyrene. The catalysts are listed in order, based on the rate for loss of allylbenzene, from most efficient to least efficient. Fahey<sup>34</sup> has shown that for *cct*-RuCl<sub>2</sub>(CO)<sub>2</sub>(PPh<sub>3</sub>)<sub>2</sub> the hydrogenation rate law is of the form rate =  $k[\text{Ru}][\text{alkene}]$ , where  $k$  contains terms for H<sub>2</sub> and PPh<sub>3</sub> concentrations.<sup>7d</sup> For each of the hydrogenations studied here a linear relationship between  $\ln[\text{allylbenzene}]_0/[\text{allylbenzene}]_t$  and time exists in support of a first-order dependence on allylbenzene.<sup>35</sup> A practical assessment of the relative catalytic activities may be gained by comparing the turnover numbers, since all reactant concentrations and conditions were the same for each experiment. Although replicate trials were carried out under the same conditions by using catalysts from the same preparation, a range of  $\pm 10\%$  in the reproducibility of the individual turnover numbers was not uncommon. The data in Table I represent averages of three replicate measurements.

The first thing that can be observed is that 1 is a bit of an anomaly. It is the only carbonyl-containing catalyst among the six most efficient catalysts. It is the most efficient catalyst for the loss of allylbenzene, but it is actually only moderately efficient for hydrogenation. It is nearly twice as efficient as the *cct* isomer for loss of allylbenzene, but only one-third more efficient as a

hydrogenation catalyst. This can be explained in terms of steric factors. The first step in the catalytic cycle is probably the creation of a vacant coordination site on the catalyst. For 1, this involves the initial loss of one of the mutually *trans* CO ligands.<sup>3,6,27</sup> Isomerization studies (vide supra) have shown that for 1 this step, promoted by the large *trans* effect of CO and the bulky PPh<sub>3</sub> ligand, is fast. However, the vacant site can be blocked or crowded by a phenyl ring in the PPh<sub>3</sub> ligand, thus promoting the rapid loss of a weakly  $\pi$ -bound substrate before hydrogenation can be affected. Blocking of the vacant coordination site in the more efficient non-carbonyl catalysts is not as important because they readily dissociate<sup>22</sup> more than one ligand.

Several general trends can be observed in the hydrogenation reactions tabulated in Table I. The most efficient catalysts for the hydrogenation of allylbenzene to propylbenzene are all non-carbonyl compounds. The only non-carbonyl compound that was not an efficient catalyst was 16. The relative efficiency of the non-carbonyl catalysts can be explained by examining their solution behavior. Compounds 2–6 have been studied by variable-temperature <sup>31</sup>P NMR spectroscopy; the data are reported elsewhere for 4,<sup>22</sup> 5,<sup>22</sup> and 16.<sup>13</sup> Compounds 2–5 decompose almost immediately upon dissolution at room temperature; 6 decomposes slowly. Decomposition occurs by phosphine dissociation, and the presence of free ligand can be detected by <sup>31</sup>P NMR spectroscopy. The vacant coordination site necessary for entrance into the hydrogenation cycle is thus readily available. The least efficient of the non-carbonyl catalysts, 16, does not decompose in solution but undergoes *trans* to *cis* isomerization that can be followed by <sup>31</sup>P NMR spectroscopy.<sup>13</sup> Of the non-carbonyls, it is the only one that can be recovered from solution, either as the *cis* isomer or as a mixture of the *trans* and *cis* isomers.

Another general trend is the relative inefficiency of all the DMPP complexes, which may be attributed to the small size and good donor ability of DMPP.<sup>4a</sup>

The relative hydrogenation efficiency (2 > 6 > 3 > 4 > 5 > 1 > 7 > 8 > 10 > 11 > 9 > 12 > 16 > 15 > 13 > 14 > 17) did not follow the same order as the relative efficiency toward the loss of allylbenzene. Catalyst 1 is only the sixth most efficient hydrogenation catalyst. The most efficient hydrogenation catalyst, 2, is coordinatively unsaturated (pentacoordinate) and readily dissociates PPh<sub>3</sub>. Its two mutually *cis* DBP ligands participate in  $\pi$ -electron overlap<sup>9</sup> that may provide some stability to the active catalyst. Furthermore, the two DBP ligands are sterically smaller than PPh<sub>3</sub> and do not block the coordination of allylbenzene to the unsaturated catalyst. Perhaps as a result of these effects, the three most efficient catalysts all contain at least 2 mol of DBP/mol of ruthenium.

For the carbonyl complexes, the DMPP complexes were again the least efficient and the PPh<sub>3</sub> monomers were the most efficient.

(34) Fahey, D. R. *J. Org. Chem.* 1973, 38, 3343.

(35) Fahey, D. R. *J. Org. Chem.* 1973, 38, 80.

**Table II.** Electrochemical Properties of Some Ru(II) Complexes<sup>a</sup>

complex	$E_{1/2} (E_{pa} - E_{pc})$ or $E_{pa}$		
	Ru(II)/Ru(I) <sup>b</sup>	Ru(II)/Ru(III)	Ru(III)/Ru(IV) <sup>b</sup>
6		0.22 (60)	1.32
8		0.68 (73)	
11		1.13 <sup>b</sup>	
13	-2.42	0.58 (60)	
14	-2.21	0.96 (58)	
15	-2.26	0.91 <sup>b</sup>	
16		0.42 <sup>c</sup> (78)	
17	-2.13	1.32 <sup>b</sup>	

<sup>a</sup> Measured by cyclic voltammetry ( $v = 200 \text{ mV s}^{-1}$ ) in  $\text{CH}_2\text{Cl}_2$  at a Pt-disk working electrode and Ag/AgCl (saturated LiCl in ethanol) reference electrode; 0.1 M tetrabutylammonium perchlorate as supporting electrolyte. All potentials are vs Fc/Fc<sup>+</sup>.  $E_{1/2}$  values are in volts and  $E_{pa} - E_{pc}$  values are in millivolts. <sup>b</sup> Chemically irreversible process; the potential cited is the peak potential. <sup>c</sup> For the *cis*-RuCl<sub>2</sub>(DMPP)<sub>4</sub>, 0.05 (77).

The dimer, **9**, was only 21% as efficient as **1**, suggesting that chloride-bridge breaking to form a monomer from this dimer is slower than losing a CO from the *cis* or *trans* monomer to form RuCl<sub>2</sub>(CO)(PPh<sub>3</sub>)<sub>2</sub>.<sup>3</sup> The hydrogenation efficiency of the DBP and DMPP complexes is geometry and stoichiometry dependent (DBP, *mer-trans* > *ttt* > *mer-cis* > *cct*; DMPP, *mer-cis* > *mer-trans* > *ttt* > *cct*). For analogous RuCl<sub>2</sub>(CO)<sub>2</sub>(PR<sub>3</sub>)<sub>2</sub> complexes<sup>6</sup> the *ttt* isomers were more active than the *cct* isomers but for the RuCl<sub>2</sub>(CO)(PR<sub>3</sub>)<sub>3</sub> complexes geometry did not influence catalytic activity because for these latter complexes geometric isomerization is rapid under catalytic conditions.

All of the catalysts studied catalyze the isomerization of allylbenzene to  $\beta$ -methylstyrene, although **6** produces no detectable *cis* isomer. For most of the catalysts, the amount of *cis*- $\beta$ -methylstyrene initially increased and then slowly decreased. The only catalysts for which isomerization did not consume more than 50% of the starting material were **2**, **3**, and **6**. Each of these is a non-carbonyl compound containing DBP. For selectivity of hydrogenation over isomerization, **6** is the most efficient catalyst. For isomerization, **1** is the most efficient catalyst. For selective promotion of isomerization over hydrogenation, the triphenylphosphine dimer, **9**, is the most efficient; it is 991% more efficient for isomerization than for hydrogenation. Compound **17** is even more selective; it is 3000% more efficient for isomerization than for hydrogenation, but the turnover numbers are so low (3 for hydrogenation, 90 for the isomerization to both isomers), that it cannot be considered an efficient catalyst.

Catalytic hydrogenation of *cis*- and *trans*- $\beta$ -methylstyrene was also studied for **5**, **7**, and **8**. The turnover number for hydrogenation of *trans*- $\beta$ -methylstyrene by **8** was 7. If we started with a mixture of 91.3% *trans*- $\beta$ -methylstyrene and 8.7% *cis*- $\beta$ -methylstyrene and used (**8**) as the catalyst, there was an initial increase of the *trans* isomer (turnover number = 2) with no formation of propylbenzene for the first 0.4 h. After that, there was no discernible isomerization, since the loss of the *cis* isomer plus the loss of the *trans* isomer equaled the net formation of propylbenzene (turnover number = 52). Isomerization and hydrogenation of *cis*- $\beta$ -methylstyrene (turnover number = 19) was slower than hydrogenation of *trans*- $\beta$ -methylstyrene (turnover number = 45). Compound **7** was a slightly more efficient catalyst having a turnover number of 11 for isomerization and hydrogenation and an overall hydrogenation turnover number of 62. Hydrogenation by **5** was even faster with an overall turnover number of 177.

Table I also lists the time required for the complete consumption of allylbenzene, the percent propylbenzene, and the total percent of *cis*- plus *trans*- $\beta$ -methylstyrenes present at that time. This essentially represents the maximum practical percent of propylbenzene produced, since hydrogenation of the internal olefins is slow. The order for the maximum number of moles of propylbenzene produced is **6** > **2** > **3** > **4** > **5** > **7** > **10** > **1** > **8** > **11** > **12** > **9** > all DMPP complexes. Other than the fact that the non-carbonyl complexes are more efficient than the carbonyl complexes, no consistent pattern emerges. On an average, the non-carbonyls hydrogenate 50% of the allylbenzene in 0.5 h. The carbonyl monomers hydrogenate an average of 22% of the allylbenzene in 0.9 h. The DMMP complexes were not used in these calculations because their efficiency was so low.

We also examined another question pertinent to catalytic efficiency, namely, recyclability. Fahey<sup>7d</sup> has shown that *cct*-RuCl<sub>2</sub>(CO)<sub>2</sub>(PPh<sub>3</sub>)<sub>2</sub> can be recycled. We tested several of the non-carbonyl complexes for recyclability by allowing a catalytic reaction to proceed until complete loss of starting substrate was observed and then adding an additional 5-mL aliquot of allylbenzene to the reaction mixture, resealing and repressurizing the vessel and observing the rates of catalysis. Less than 1% of the catalysts were lost in the aliquots withdrawn to determine the end of each cycle. The catalysts were active through two successive runs, although with a 4-fold loss of efficiency in the second run and an even greater decrease in efficiency in the third run.

**Electrochemistry.** If the rate-determining step in the catalytic hydrogenation were oxidative addition of H<sub>2</sub> to the coordinatively unsaturated ruthenium species,<sup>3</sup> one might expect<sup>3b</sup> the ease of oxidative addition to parallel the oxidation potential of the complex. Thus, we have investigated the electrochemical behavior of some of these complexes (Table II). The redox potentials for the Ru(II)/Ru(III) processes are a function of the complex geometry, stoichiometry, and the nature of the phosphole. They are similar in magnitude to those reported<sup>8</sup> for similar phosphine complexes. For complexes **8**, **13**, and **14**, this process is electrochemically reversible and is followed by a slow chemical step. The follow-up chemical step for the other three complexes, **11**, **15**, and **17**, is fast, as no cathodic wave can be seen on the return sweep, even at high scan rates. Also, as found<sup>8</sup> for analogous phosphine complexes, the RuCl<sub>2</sub>(CO)(phosphole)<sub>3</sub> complexes are generally easier to oxidize than the RuCl<sub>2</sub>(CO)<sub>2</sub>(phosphole)<sub>2</sub> complexes. The DMPP complexes are easier to oxidize than the comparable DBP complexes, and the *trans* or *ttt* isomers are easier to oxidize than their *cis* or *cct* counterparts. The oxidation potentials for the *trans*-RuCl<sub>2</sub>(CO)(PR<sub>3</sub>)<sub>3</sub> complexes provide an assessment of the relative donor abilities of these phosphorus ligands toward ruthenium(II), which decrease in the order PhMe<sub>2</sub>P (0.55 V)<sup>8</sup> > DMPP (0.58 V) > Ph<sub>2</sub>MeP (0.61 V)<sup>8</sup> > DBP (0.68 V). This range is small, however, suggesting that the donor abilities are not drastically different.

The compounds in Table II are listed in terms of decreasing catalytic efficiency for the loss of allylbenzene (Table I). Clearly, the Ru(II)/Ru(III) oxidation potentials do not follow the same order as their catalytic efficiency. This implies that oxidative addition of H<sub>2</sub> is probably not the rate-limiting step for entry into the catalytic cycle.<sup>8</sup>

**Acknowledgment** is made to the donors of the Petroleum Research Fund, administered by the American Chemical Society, for financial support.